

# ChainLink

## A Decentralized Oracle Network

Steve Ellis, Ari Juels<sup>†</sup>, and Sergey Nazarov

4 September 2017 (v1.0)

### Abstract

Smart contracts are poised to revolutionize many industries by replacing the need for both traditional legal agreements and centrally automated digital agreements. Both performance verification and execution rely on manual actions from one of the contracting parties, or an automated system that programmatically retrieves and updates relevant changes. Unfortunately, because of their underlying consensus protocols, the blockchains on which smart contracts run cannot support native communication with external systems.

Today, the solution to this problem is to introduce a new functionality, called an *oracle*, that provides connectivity to the outside world. Existing oracles are centralized services. Any smart contract using such services has a single point of failure, making it no more secure than a traditional, centrally run digital agreement.

In this paper we present ChainLink, a decentralized oracle network. We describe the on-chain components that ChainLink provides for contracts to gain external connectivity, and the software powering the nodes of the network. We present both a simple on-chain contract data aggregation system, and a more efficient off-chain consensus mechanism. We also describe supporting reputation and security monitoring services for ChainLink that help users make informed provider selections and achieve robust service even under aggressively adversarial conditions. Finally, we characterize the properties of an ideal oracle as guidance for our security strategy, and lay out possible future improvements, including richly featured oracle programming, data-source infrastructure modifications, and confidential smart-contract execution.

# Contents

<b>1</b>	<b>Introduction</b>	<b>3</b>
<b>2</b>	<b>Architectural Overview</b>	<b>4</b>
2.1	On-Chain Architecture . . . . .	5
2.2	Off-Chain Architecture . . . . .	6
<b>3</b>	<b>Oracle Security</b>	<b>7</b>
<b>4</b>	<b>ChainLink Decentralization Approach</b>	<b>11</b>
4.1	Distributing sources . . . . .	11
4.2	Distributing oracles . . . . .	11
<b>5</b>	<b>ChainLink Security Services</b>	<b>16</b>
5.1	Validation System . . . . .	16
5.2	Reputation System . . . . .	17
5.3	Certification Service . . . . .	19
5.4	Contract-Upgrade Service . . . . .	20
5.5	LINK token usage . . . . .	21
<b>6</b>	<b>Long-Term Technical Strategy</b>	<b>21</b>
6.1	Confidentiality . . . . .	21
6.2	Infrastructure changes . . . . .	25
6.3	Off-chain computation . . . . .	26
<b>7</b>	<b>Existing Oracle Solutions</b>	<b>26</b>
<b>8</b>	<b>Conclusion</b>	<b>27</b>
<b>A</b>	<b>Off-Chain Aggregation</b>	<b>33</b>
A.1	OCA protocol . . . . .	34
A.2	Proof sketches . . . . .	36
A.3	Discussion . . . . .	37
<b>B</b>	<b>SGX Trust Assumptions</b>	<b>38</b>

# 1 Introduction

Smart contracts are applications that execute on decentralized infrastructure, such as a blockchain. They are tamperproof, in the sense that no party (even their creator) can alter their code or interfere with their execution. Historically, contracts embodied in code have run in a centralized manner that leaves them subject to alteration, termination, and even deletion by a privileged party. In contrast, smart contracts' execution guarantees, which bind all parties to an agreement as written, create a new and powerful type of trust relationship that does not rely on trust in any one party. Because they are self-verifying and self-executing (i.e., tamperproof as explained above), smart contracts thus offer a superior vehicle for realizing and administering digital agreements.

The powerful new trust model that smart contracts embody, though, introduces a new technical challenge: *connectivity*. The vast majority of interesting[27]<sup>1</sup> smart contract applications rely on data about the real world that comes from key resources, specifically data feeds and APIs, that are external to the blockchain. Because of the mechanics of the consensus mechanisms underpinning blockchains, a blockchain cannot directly fetch such critical data.

We propose a solution to the smart contract connectivity problem in the form of ChainLink, a secure oracle network. What differentiates ChainLink from other oracle solutions is its ability to operate as a fully decentralized network. This decentralized approach limits the trust in any single party, enabling the tamperproof quality valued in smart contracts to be extended to the end-to-end operation between smart contracts and the APIs they rely on. Making smart contracts externally aware, meaning capable of interacting with off-chain resources, is necessary if they are going to replace the digital agreements in use today.

Today, the lion's share of traditional contractual agreements that have been digitally automated use external data to prove contractual performance, and require data outputs to be pushed to external systems. When smart contracts replace these older contractual mechanisms, they will require high-assurance versions of the same types of data inputs and outputs. Examples of potential next-generation smart contracts and their data requirements include:

- *Securities smart contracts* such as bonds, interest rate derivatives, and many others will require access to APIs reporting market prices and market reference data, e.g. interest rates.

---

<sup>1</sup>The main use of smart contracts in Ethereum today is management of tokens, which are a common functionality in most smart contract networks. We believe that the current focus on tokens to the exclusion of many other possible applications is due to a lack of adequate oracle services, a situation ChainLink specifically aims to remedy.

- *Insurance smart contracts* will need data feeds about IoT data related to the insurable event in question, e.g.: was the warehouse’s magnetic door locked at the time of breach, was the company’s firewall online, or did the flight you had insurance for arrive on time.
- *Trade finance smart contracts* will need GPS data about shipments, data from supply chain ERP systems, and customs data about the goods being shipped in order to confirm fulfillment of contractual obligations.

Another problem common to these examples is the inability for smart contracts to output data into off-chain systems. Such output often takes the form of a payment message routed to traditional centralized infrastructure in which users already have accounts, e.g., for bank payments, PayPal, and other payment networks. ChainLink’s ability to securely push data to APIs and various legacy systems on behalf of a smart contract permits the creation of externally-aware tamperproof contracts.

## Whitepaper roadmap

In this whitepaper\*, we review the ChainLink architecture (Section 2). We then explain how we define security for oracles (Section 3). We describe the ChainLink approach to decentralization / distribution of oracles and data sources (Section 4), and follow with a discussion of the four security services proposed by ChainLink, as well as the role played by LINK tokens (Section 5). We then describe a proposed long-term development strategy, which includes better confidentiality protections, the use of trusted hardware, infrastructure changes, and general oracle programmability (Section 6). We briefly review alternative oracle designs (Section 7), and conclude with a short discussion of the design principles and philosophy guiding ChainLink development (Section 8).

## 2 Architectural Overview

ChainLink’s core functional objective is to bridge two environments: on-chain and off-chain. We describe the architecture of each ChainLink component below. ChainLink will initially be built on Ethereum [16], [35], but we intend for it to support all leading smart contract networks for both off-chain and cross-chain interactions. In both its on and off-chain versions, ChainLink has been designed with modularity in mind. Every piece of the ChainLink system is upgradable, so that different components can be replaced as better techniques and competing implementations arise.

## 2.1 On-Chain Architecture

As an oracle service, ChainLink nodes return replies to data *requests* or *queries* made by or on behalf of a user contract, which we refer to as *requesting contracts* and denote by **USER-SC**. ChainLink’s on-chain interface to requesting contracts is itself an on-chain contract that we denote by **CHAINLINK-SC**.

Behind **CHAINLINK-SC**, ChainLink has an on-chain component consisting of three main contracts: a *reputation contract*, an *order-matching contract*, and an *aggregating contract*. The reputation contract keeps track of oracle-service-provider performance metrics. The order-matching smart contract takes a proposed service level agreement, logs the SLA parameters, and collects bids from oracle providers. It then selects bids using the reputation contract and finalizes the oracle SLA. The aggregating contract collects the oracle providers’ responses and calculates the final collective result of the ChainLink query. It also feeds oracle provider metrics back into the reputation contract. ChainLink contracts are designed in a modular manner, allowing for them to be configured or replaced by users as needed. The on-chain work flow has three steps: 1) oracle selection, 2) data reporting, 3) result aggregation.

**Oracle Selection** An oracle services purchaser specifies requirements that make up a service level agreement (SLA) proposal. The SLA proposal includes details such as query parameters and the number of oracles needed by the purchaser. Additionally, the purchaser specifies the reputation and aggregating contracts to be used for the rest of the agreement.

Using the reputation maintained on-chain, along with a more robust set of data gathered from logs of past contracts, purchasers can manually sort, filter, and select oracles via off-chain listing services. Our intention is for ChainLink to maintain one such listing service, collecting all ChainLink-related logs and verifying the binaries of listed oracle contracts. We further detail the listing service and reputation systems in Section 5. The data used to generate listings will be pulled from the blockchain, allowing for alternative oracle-listing services to be built. Purchasers will submit SLA proposals to oracles off-chain, and come to agreement before finalizing the SLA on-chain.

Manual matching is not possible for all situations. For example, a contract may need to request oracle services dynamically in response to its load. Automated solutions solve this problem and enhance usability. For these reasons, automated oracle matching is also being proposed by ChainLink through the use of order-matching contracts.

Once the purchaser has specified their SLA proposal, instead of contacting the oracles directly, they will submit the SLA to an order-matching contract. The submission of the proposal to the order-matching contract triggers a log that oracle providers can

monitor and filter based on their capabilities and service objectives. ChainLink nodes then choose whether to bid on the proposal or not, with the contract only accepting bids from nodes that meet the SLA's requirements. When an oracle service provider bids on a contract, they commit to it, specifically by attaching the penalty amount that would be lost due to their misbehavior, as defined in the SLA.

Bids are accepted for the entirety of the bidding window. Once the SLA has received enough qualified bids and the bidding window has ended, the requested number of oracles is selected from the pool of bids. Penalty payments that were offered during the bidding process are returned to oracles who were not selected, and a finalized SLA record is created. When the finalized SLA is recorded it triggers a log notifying the selected oracles. The oracles then perform the assignment detailed by the SLA.

**Data Reporting** Once the new oracle record has been created, the off-chain oracles execute the agreement and report back on-chain. For more detail about off-chain interactions, see Sections 2.2 and 4.

**Result Aggregation** Once the oracles have revealed their results to the oracle contract, their results will be fed to the aggregating contract. The aggregating contract tallies the collective results and calculates a weighted answer. The validity of each oracle response is then reported to the reputation contract. Finally, the weighted answer is returned to the specified contract function in USER-SC.

Detecting outlying or incorrect values is a problem that is specific to each type of data feed and application. For instance, detecting and rejecting outlying answers before averaging may be necessary for numeric data but not boolean. For this reason, there will not be a specific aggregating contract, but a configurable contract address which is specified by the purchaser. ChainLink will include a standard set of aggregating contracts, but customized contracts may also be specified, provided they conform to the standard calculation interface.

## 2.2 Off-Chain Architecture

Off-chain, ChainLink initially consists of a network of oracle nodes connected to the Ethereum network, and we intend for it to support all leading smart contract networks. These nodes independently harvest responses to off-chain requests. As we explain below, their individual responses are aggregated via one of several possible consensus mechanisms into a global response that is returned to a requesting contract USER-SC. The ChainLink nodes are powered by the standard open source core implementation which handles standard blockchain interactions, scheduling, and connecting with common external resources. Node operators may choose to add software

extensions, known as external adapters, that allow the operators to offer additional specialized off-chain services. ChainLink nodes have already been deployed alongside both public blockchains and private networks in enterprise settings; enabling the nodes to run in a decentralized manner is the motivation for the ChainLink network.

**ChainLink Core.** The core node software is responsible for interfacing with the blockchain, scheduling, and balancing work across its various external services. Work done by ChainLink nodes is formatted as *assignments*. Each assignment is a set of smaller job specifications, known as subtasks, which are processed as a pipeline. Each subtask has a specific operation it performs, before passing its result onto the next subtask, and ultimately reaching a final result. ChainLink’s node software comes with a few subtasks built in, including HTTP requests, JSON parsing, and conversion to various blockchain formats.

**External Adapters.** Beyond the built-in subtask types, custom subtasks can be defined by creating *adapters*. Adapters are external services with a minimal REST API. By modeling adapters in a service-oriented manner, programs in any programming language can be easily implemented simply by adding a small intermediate API in front of the program. Similarly, interacting with complicated multi-step APIs can be simplified to individual subtasks with parameters.

**Subtask Schemas.** We anticipate that many adapters will be open sourced, so that services can be audited and run by various community members. With many different types of adapters being developed by many different developers, ensuring compatibility between adapters is essential.

ChainLink currently operates with a schema system based on JSON Schema [36], to specify what inputs each adapter needs and how they should be formatted. Similarly, adapters specify an output schema to describe the format of each subtask’s output.

### 3 Oracle Security

In order to explain ChainLink’s security architecture, we must first explain why security is important—and what it means.

**Why must oracles be secure?** Returning to our simple examples in Section 1, if a smart contract security gets a false data feed, it may payout the incorrect party, if smart contract insurance data feeds can be tampered with by the insured party

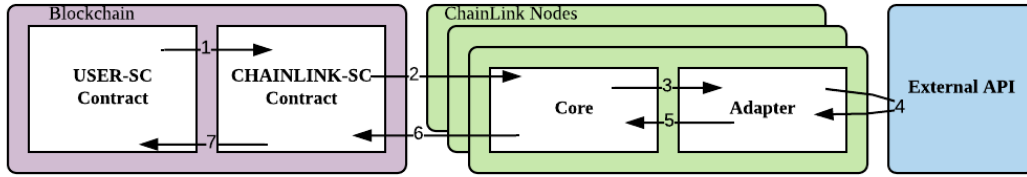

**Figure 1:** ChainLink workflow: **1)** USER-SC makes an on-chain request; **2)** CHAINLINK-SC logs an event for the oracles; **3)** ChainLink core picks up the event and routes the assignment to an adapter; **4)** ChainLink adapter performs a request to an external API; **5)** ChainLink adapter processes the response and passes it back to the core; **6)** ChainLink core reports the data to CHAINLINK-SC; **7)** CHAINLINK-SC aggregates responses and passes them back as a single response to USER-SC.

there may be insurance fraud, and if GPS data given to a trade finance contract can be modified after it leaves the data provider, payment can be released for goods that haven't arrived.

More generally, a well-functioning blockchain, with its ledger or bulletin-board abstraction, offers very strong security properties. Users rely on the blockchain as a functionality that correctly validates transactions and prevents data from being altered. They treat it in effect like a trusted third party (a concept we discuss at length below). A supporting oracle service must offer a level of security commensurate with that of the blockchain it supports. An oracle too must therefore serve users as an effective trusted third party, providing correct and timely responses with very high probability. The security of any system is only as strong as its weakest link, so a highly trustworthy oracle is required to preserve the trustworthiness of a well-engineered blockchain.

**Defining oracle security: An ideal view.** In order to reason about oracle security, we must first define it. An instructive, principled way to reason about oracle security stems from the following thought experiment. Imagine that a trusted third party (TTP)—an ideal entity or functionality that always carries out instructions faithfully to the letter—were tasked with running an oracle. We'll denote this oracle by **ORACLE** (using all caps in general to denote an entity fully trusted by users), and suppose that the TTP obtains data from a perfectly trustworthy data source **Src**. Given this magical service **ORACLE**, what instructions would we ask it to carry out?

To achieve the property of integrity, also referred to as the authenticity property [24], we would simply ask that **ORACLE** perform the following steps:



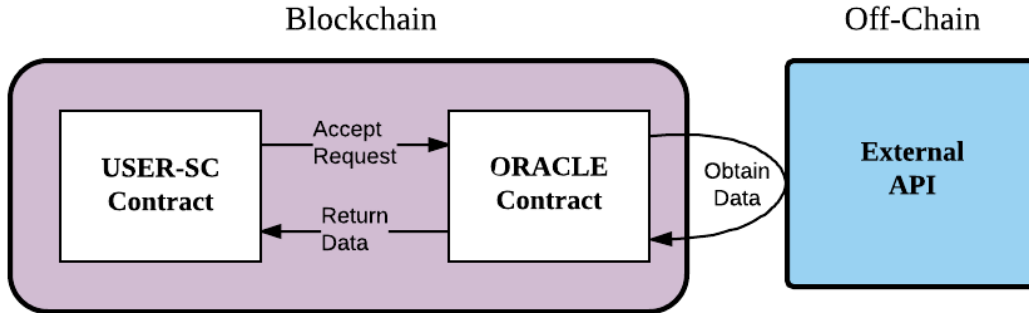

**Figure 2:** Behavior of an ideal oracle ORACLE is defined by steps: **1)** Accept request; **2)** Obtain data; **3)** Return data. Additionally, to protect the confidentiality of a request, upon decrypting it, ORACLE never uses or reveals the data it contains, except to query **Src**.

1. *Accept request:* Ingest from a smart contract USER-SC a request  $\text{Req} = (\text{Src}, \tau, q)$  that specifies a target data source **Src**, a time or range of times  $\tau$ , and a query  $q$ ;
2. *Obtain data:* Send query  $q$  to **Src** at time  $\tau$ ;
3. *Return data:* On receiving answer  $a$ , return  $a$  to the smart contract.

These simple instructions, correctly carried out, define a strong, meaningful, but simple notion of security. Intuitively, they dictate that ORACLE acts as a trustworthy bridge between **Src** and USER-SC.<sup>2</sup> For example, if **Src** is `https://www.FountOfKnowledge.com`,  $\tau$  is 4 p.m., and  $q = \text{"price for ticker INTC"}$ , the integrity of ORACLE guarantees that it will provide USER-SC with exactly the price of INTC as queried at 4 p.m. at `https://www.FountOfKnowledge.com`.

*Confidentiality* is another desirable property for oracles. As USER-SC sends  $\text{Req}$  to ORACLE in the clear on the blockchain,  $\text{Req}$  is *public*. There are many situations in which  $\text{Req}$  is sensitive and its publication could be harmful. If USER-SC is a flight insurance contract, for example, and sends ORACLE a query  $\text{Req}$  regarding a particular user’s flight ( $q = \text{"Ether Air Flight 338"}$ ), the result would be that a user’s flight plans are revealed to the whole world. If USER-SC is a contract for

<sup>2</sup>Of course, many details are omitted here. ORACLE should communicate with both USER-SC and source **Src** over secure, i.e., tamperproof, channels. (If **Src** is a web server, TLS is required. To communicate with USER-SC, ORACLE must be sure to scrape the right blockchain and digitally sign  $A$  appropriately.)

financial trading, `Req` could leak information about a user's trades and portfolio. There are many other examples, of course.

To protect the confidentiality of `Req`, we can require that data in `Req` be encrypted under a (public key) belonging to `ORACLE`. Continuing to leverage the TTP nature of `ORACLE`, we could then simply give `ORACLE` the information-flow constraint:

*Upon decrypting `Req`, never reveal or use data in `Req` except to query `Src`.*

There are other important oracle properties, such as availability, the last of the classical CIA (Confidentiality-Integrity-Availability) triad. A truly ideal service `ORACLE`, of course, would never go down. Availability also encompasses more subtle properties such as censorship resistance: An honest `ORACLE` will not single out particular smart contracts and deny their requests.

The concept of a trusted third party is similar to the notion of an ideal functionality [7] used to prove the security of cryptographic protocols in certain models. We can also model a blockchain in similar terms, conceptualizing it in terms of a TTP that maintains an ideal bulletin board. Its instructions are to accept transactions, validate them, serialize them, and maintain them permanently on the bulletin board, an append-only data structure.

**Why the ideal oracle (`ORACLE`) is hard to achieve.** There is, of course, no perfectly trustworthy data source `Src`. Data may be benignly or maliciously corrupted due to faulty web sites, cheating service providers, or honest mistakes.

If `Src` isn't trustworthy, then even if `ORACLE` does operate exactly like a TTP as instructed above, it still doesn't completely meet the notion of security we want. Given a faulty source `Src`, the integrity property defined above no longer means that an oracle's answer  $a$  is correct. If the true price of Intel is \$40 and `https://www.FountOfKnowledge.com` misreports it as \$50, for example, then `ORACLE` will send the incorrect value  $a = \$50$  to `USER-SC`. This problem is unavoidable when using a single source `Src`. `ORACLE` simply has no way to know whether the answers `Src` provides to its queries are correct.

A bigger issue, of course, is the fact that our TTP for `ORACLE` is just an abstraction. No service provider is unconditionally trustworthy. Even the best-intentioned may be buggy or hacked. So there is no way to for a user or smart contract to have absolute assurance that a service `ORACLE` will carry out its instructions faithfully.

ChainLink reasons about its security protocols in terms of this ideal functionality `ORACLE`. Our goal in ChainLink is to achieve a real world system with *properties as close as possible to those of `ORACLE`* under realistic trust assumptions. We now explain how.

For simplicity in what follows, we now denote by `CHAINLINK-SC` the complete set of ChainLink contracts, i.e., its full on-chain functionality (not just its interface

to requesting contracts). We thereby abstract away the multiple individual contracts actually used in the system architecture.

## 4 ChainLink Decentralization Approach

We propose three basic complementary approaches to ensuring against faulty nodes: (1) Distribution of data sources; (2) Distribution of oracles; and (3) Use of trusted hardware. We discuss the first two approaches, which involve *decentralization*, in this section. We discuss our long-term strategy for trusted hardware, a different and complementary approach, in Section 6.

### 4.1 Distributing sources

A simple way to deal with a faulty single source **Src** is to obtain data from *multiple* sources, i.e., distribute the data source. A trustworthy ORACLE can query a collection of sources **Src**<sub>1</sub>, **Src**<sub>2</sub>, . . . , **Src**<sub>k</sub>, obtain responses  $a_1, a_2, \dots, a_k$ , and aggregate them into a single answer  $A = \text{agg}(a_1, a_2, \dots, a_k)$ . ORACLE might do this in any of a number of ways. One, for example, is majority voting. If a majority of sources return the identical value  $a$ , the function **agg** returns  $a$ ; otherwise it returns an error. In this case, provided that a majority ( $> k/2$ ) sources are functioning correctly, ORACLE will always return a correct value  $A$ .

Many alternative functions **agg** can ensure robustness against erroneous data or handle fluctuations in data values over time (e.g, stock prices). For example, **agg** might discard outliers (e.g., the largest and smallest values  $a_i$ ) and output the mean of the remaining ones.

Of course, faults may be correlated across data sources in a way that weakens the assurances provided by aggregation. If site **Src**<sub>1</sub> = **EchoEcho.com** obtains its data from **Src**<sub>2</sub> = **TheHorsesMouth.com**, an error at **Src**<sub>2</sub> will always imply an error at **Src**<sub>1</sub>. More subtle correlations between data sources can also occur. Chainlink also proposes to pursue research into mapping and reporting the independence of data sources in an easily digestible way so that oracles and users can avoid undesired correlations.

### 4.2 Distributing oracles

Just as sources can be distributed, our ideal service ORACLE itself can be approximated as a distributed system. This is to say that instead of a single monolithic oracle node  $O$ , we can instead have a collection of  $n$  different oracle nodes  $\{O_1, O_2, \dots, O_n\}$ . Each oracle  $O_i$  contacts its own distinct set of data sources which may or may not

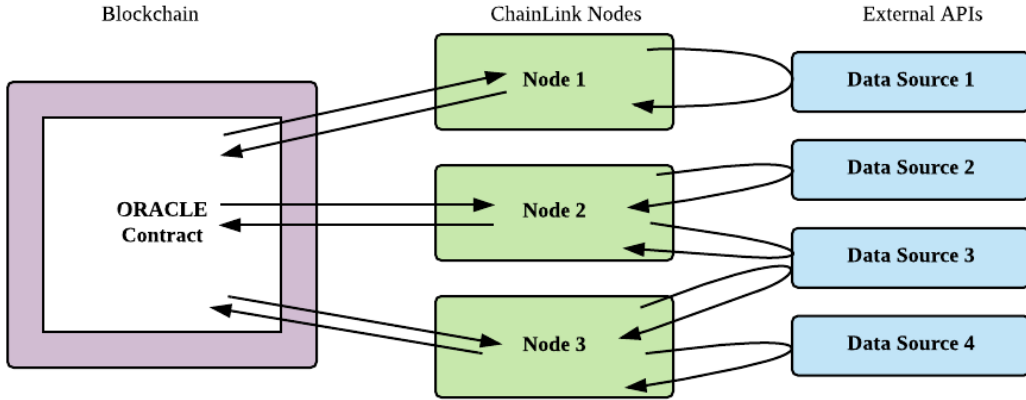

**Figure 3:** Requests are distributed across both oracles and data sources. This figure shows an example of such two-level distribution.

overlap with those of other oracles.  $O_i$  aggregates responses from its data sources and outputs its own distinct answer  $A_i$  to a query Req.

Some of these oracles may be faulty. So clearly the set of all oracles' answers  $A_1, A_2, \dots, A_n$  will need to be aggregated in a trustworthy way into a single, authoritative value  $A$ . But given the possibility of faulty oracles, where and how will this aggregation happen in ChainLink?

**Initial solution: In-contract aggregation.** Our initial proposed solution in ChainLink will be a simple one called *in-contract aggregation*. CHAINLINK-SC—which, again, denotes the on-chain part of ChainLink—will itself aggregate oracle responses. (Alternatively, CHAINLINK-SC may call another aggregation contract, but for conceptual simplicity we assume that the two components form a single contract.) In other words, CHAINLINK-SC will compute  $A = \text{Agg}(A_1, A_2, \dots, A_n)$  for some function  $\text{Agg}$  (similar to  $\text{agg}$ , as described above), and send the result  $A$  to USER-SC.

This approach is practical for small  $n$ , and has several distinct benefits:

- *Conceptual simplicity:* Despite the fact that the oracle is distributed, a single entity, CHAINLINK-SC, performs aggregation by executing  $\text{Agg}$ .
- *Trustworthiness:* As CHAINLINK-SC's code can be publicly inspected, its correct behavior can be verified. (CHAINLINK-SC will be a relatively small, simple piece of code.) Additionally, CHAINLINK-SC's execution is fully visible on-

chain. Thus users, i.e., creators of USER-SC, can achieve a high degree of trust in CHAINLINK-SC.

- *Flexibility*: CHAINLINK-SC can implement most desired aggregation functions Agg—the majority function, averaging, etc.

Simple as it is, this approach presents a novel and interesting technical challenge, namely the problem of *freeloading*. A cheating oracle  $O_z$  can observe the response  $A_i$  of another oracle  $O_i$  and copy it. In this way, oracle  $O_z$  avoids the expense of querying data sources, which may charge per-query fees. Freeloading weakens security by undermining the diversity of data source queries and also disincentivizes oracles from responding quickly: Responding slowly and freeloading is a cheaper strategy.

We suggest a well known solution to this problem, namely the use of a commit / reveal scheme. In a first round, oracles send CHAINLINK-SC cryptographic commitments to their responses. After CHAINLINK-SC has received a quorum of responses, it initiates a second round in which oracles reveal their responses.

Algorithm 1 shows a simple sequential protocol that guarantees availability given  $3f + 1$  nodes. It uses a commit / reveal scheme to prevent freeloading. Oracle responses are decommitted, and thus exposed to a potential freeloader only *after* all commitments have been made, thereby excluding the freeloader from copying other oracles' responses.

On-chain protocols can leverage block times to support synchronous protocol designs. In ChainLink, however, oracle nodes obtain data from sources that may have highly variable response times, and decommitment times by nodes can vary due to, e.g., use of different gas prices in Ethereum. To ensure the fastest possible protocol responsiveness, therefore, Alg. 1 is designed as an asynchronous protocol.

Here,  $\text{Commit}_r(A)$  denotes a commitment of value  $A$  with witness  $r$ , while  $\text{SID}$  denotes the set of valid session ids. The protocol assumes authenticated channels among all players.

It is easy to see that Alg. 1 will terminate successfully. Given  $3f + 1$  nodes in total, at most  $f$  are faulty, so at least  $2f + 1$  will send commitments in Step 4. Of those commitments, at most  $f$  come from faulty nodes, so at least  $f + 1$  come from honest nodes. All such commitments will eventually be decommitted.

Additionally, it is easy to see that  $A$  will be correct in Alg.1. Of the  $f + 1$  decommitments on the single value  $A$ , at least one has to come from an honest node.

In-contract aggregation via Alg. 1 will be the main approach supported by ChainLink in the short term. The proposed initial implementation will involve a more sophisticated, concurrent variant of the algorithm. Our longer-term proposal is reflected in the rather more complicated protocol OCA (Off-Chain Aggregation) specified in Algorithms 2 and 3 in Appendix A. OCA is an off-chain aggregation protocol that

---

**Algorithm 1** InChainAgg( $\{O_i\}_{i=1}^n$ ) (code for CHAINLINK-SC)

---

- 1: Wait until Req is received from USER-SC.
  - 2:  $\text{sid} \leftarrow_{\$} \text{SID}$
  - 3: Broadcast (request, sid).
  - 4: Wait until set  $C$  of  $2f + 1$  messages (commit,  $c_i = \text{Commit}_{r_i}(A_i), \text{sid}$ ) from distinct  $O_i$  are received.
  - 5: Broadcast (committed, sid).
  - 6: Wait until set  $D$  of  $f + 1$  distinct valid decommitments (decommit,  $(r_i, A_i), \text{sid}$ ) are received where, for some  $A$ , all  $A_i = A$ .
  - 7: Send (Answer,  $A, \text{sid}$ ) to USER-SC.
- 

minimizes on-chain transaction costs. That protocol also includes payment to oracle nodes and ensures against payments to freeloaders.

**Medium-term strategy: Off-chain aggregation.** In-contract aggregation has a key disadvantage: Cost. It incurs the cost of transmitting and processing on-chain  $O(n)$  oracle messages (commits and reveals for  $A_1, A_2, \dots, A_n$ ). In permissioned blockchains, this overhead may be acceptable. In permissionless blockchains with on-chain transaction fees such as Ethereum, if  $n$  is large, the costs can be prohibitive. A more cost-effective approach is to aggregate oracle responses off-chain and transmit a single message to CHAINLINK-SC  $A$ . We propose deployment of this approach, called *off-chain aggregation*, in the medium-to-long term.

The problem of achieving a consensus value  $A$  in the face of potentially faulty nodes is much like the problem of consensus that underpins blockchains themselves. Given a predetermined set of oracles, one might consider using a classical Byzantine Fault Tolerant (BFT) consensus algorithm to compute  $A$ . Classical BFT protocols, however, aim to ensure that at the end of a protocol invocation, all honest nodes store the same value, e.g., in a blockchain, that all nodes store the same fresh block. In our oracle setting, the goal is slightly different. We want to ensure that CHAINLINK-SC (and then USER-SC) obtains aggregate answer  $A = \text{Agg}(A_1, A_2, \dots, A_n)$  *without participating in the consensus protocol and without needing to receive answers from multiple oracles*. The problem of freeloading, moreover, still needs to be addressed.

The ChainLink system proposes the use of a simple protocol involving threshold signatures. Such signatures can be realized using any of a number of signature schemes, but are especially simple to implement using Schnorr signatures [4]. In this approach, oracles have a collective public key  $\text{pk}$  and a corresponding private key  $\text{sk}$  that is shared among  $O_1, O_2, \dots, O_n$  in a  $(t, n)$ -threshold manner [3]. Such a sharing means that every node  $O_i$  has a distinct private / public keypair  $(\text{sk}_i, \text{pk}_i)$ .  $O_i$  can

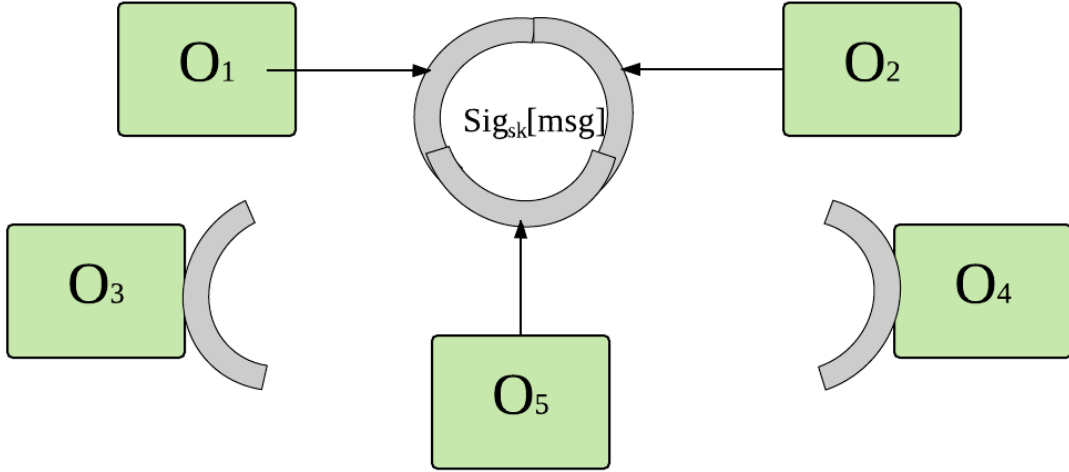

**Figure 4:**  $\text{Sig}_{\text{sk}}[A]$  can be achieved by any  $n/2+1$  of the oracles.

generate a partial signature  $\sigma_i = \text{Sig}_{\text{sk}_i}[A_i]$  that can be verified with respect to  $\text{pk}_i$ .

The key feature of this setup is that partial signatures on the same value  $A$  can be aggregated across any set of  $t$  oracles to yield a single valid *collective* signature  $\Sigma = \text{Sig}_{\text{sk}}[A]$  on an answer  $A$ . No set of  $t - 1$  oracles, however, can produce a valid signature on any value. The single signature  $\Sigma$  thus implicitly embodies the partial signatures of at least  $t$  oracles.

Threshold signatures can be realized naïvely by letting  $\Sigma$  consist explicitly of a set of  $t$  valid, independent signatures from individual nodes. Threshold signatures have similar security properties to this naïve approach. But they provide a significant on-chain performance improvement: They reduce the size and cost of verifying  $\Sigma$  by a factor of  $t$ .

With this setup, it would seem that oracles can just generate and broadcast partial signatures until  $t$  such partial signatures enable the computation of  $\Sigma$ . Again, though, the problem of freeloading arises. We must therefore ensure that oracles genuinely obtain data from their designated sources, rather than cheating and copying  $A_i$  from another oracle. Our solution involves a financial mechanism: An entity PROVIDER (realizable as a smart contract) rewards only oracles that have sourced original data for their partial signatures.

In a distributed setting, determining which oracles qualify for payment turns out to be tricky. Oracles may intercommunicate off-chain and we no longer have a single authoritative entity (CHAINLINK-SC) receiving responses and are therefore un-

able to identify eligible payees directly among participating oracles. Consequently, PROVIDER must obtain evidence of misbehavior from the oracles themselves, some of which may be untrustworthy. We propose the use of consensus-like mechanisms in our solution for ChainLink to ensure that PROVIDER does not pay freeloading oracles.

The off-chain aggregation system we propose for ChainLink, with accompanying security proof sketches, may be found in Appendix A. It makes use of a distributed protocol based on threshold signatures that provides resistance to freeloading by  $f < n/3$  oracles. We believe resistance to freeloading is an interesting new technical problem.

## 5 ChainLink Security Services

Thanks to the protocols we have just described in the previous section, ChainLink proposes to ensure availability and correctness in the face of up to  $f$  faulty oracles. Additionally, trusted hardware, as discussed in Section 6, is being actively considered as a secure approach toward protecting against corrupted oracles providing incorrect responses. Trusted hardware, however, may not provide definitive protection for three reasons. First, it will not be deployed in initial versions of the ChainLink network. Second, some users may not trust trusted hardware (see Appendix B for a discussion). Finally, trusted hardware cannot protect against node downtime, only against node misbehavior. Users will therefore wish to ensure that they can choose the most reliable oracles and minimize the probability of USER-SC relying on  $> f$  faulty oracles.

To this end, we propose the use of four key *security services*: a *Validation System*, a *Reputation System*, a *Certification Service*, and a *Contract-Upgrade Service*. All of these services may initially be run by one company or group interested in launching the ChainLink network, but are designed to *operate strictly accordingly to ChainLink's philosophy of decentralized design*. ChainLink's proposed security services cannot block oracle node participation or alter oracle responses. The first three services only provide ratings or guidance to users, while the Contract-Upgrade Service is entirely optional for users. Additionally, these services are designed to support independent providers, whose participation should be encouraged so that users will eventually have multiple security services among which to choose.

### 5.1 Validation System

The ChainLink Validation System monitors on-chain oracle behavior, providing an objective performance metric that can guide user selection of oracles. It will seek to monitor oracles for:



- *Availability*: The Validation System should record failures by an oracle to respond in a timely way to queries. It will compile ongoing uptime statistics.
- *Correctness*: The Validation System should record apparent erroneous responses by an oracle as measured by deviations from responses provided by peers.<sup>3</sup>

In our initial, on-chain aggregation system in ChainLink, such monitoring is straightforward, as all oracle activity is visible to CHAINLINK-SC.

Recall, however, that in the off-chain aggregation system envisaged for ChainLink, it's the oracles themselves that perform aggregation. Consequently, CHAINLINK-SC does not have direct visibility into oracle responses and cannot itself monitor availability and correctness.

Fortunately, oracles digitally sign their responses, and thus, as a side effect, generate non-repudiable evidence of their answers. Our proposed approach will therefore be to realize the validation service as a smart contract that would reward oracles for submitting evidence of deviating responses. In other words, oracles would be incentivized to report apparently erroneous behavior.

Availability is somewhat trickier to monitor, as oracles of course don't sign their failures to respond. Instead, a proposed protocol enhancement would require oracles to digitally sign attestations to the set of responses they have received from other oracles. The validation contract would then accept (and again reward) submission of sets of attestations that demonstrate consistent non-responsiveness by an underperforming oracle to its peers.

In both the on-chain and off-chain cases, availability and correctness statistics for oracles will be visible *on-chain*. Users / developers will thus be able to view them in real time through an appropriate front end, such as a Dapp in Ethereum or an equivalent application for a permissioned blockchain.

## 5.2 Reputation System

The Reputation System proposed for ChainLink would record and publish user ratings of oracle providers and nodes, offering a means for users to evaluate oracle performance holistically. Validator System reports are likely to be a major factor in determining oracle reputations and placing these reputations on a firm footing of trust. Factors beyond on-chain history, though, can provide essential information about oracle node

---

<sup>3</sup>“Deviation” must be defined in a data-specific manner. For simple boolean responses—for example, whether a flight arrived on time—deviation simply means a response opposite that of the majority. For, say, the temperature of a city, which may vary legitimately across sensors and sources, deviation may mean significant numerical deviation. Of course, for various reasons, e.g., broken sensors, even a well-functioning oracle may deviate from the majority answer some fraction of the time.

security profiles. These may include users' familiarity with oracles' brands, operating entities, and architectures. We envision the ChainLink Reputation System to include a basic on-chain component where users' ratings would be available for other smart contracts to reference. Additionally, reputation metrics should be easily accessible off-chain where larger amounts of data can be efficiently processed and more flexibly weighted.

For a given oracle operator, the Reputation System is initially proposed as supporting the following metrics, both at the granularity of specific assignment types (see Section 2), and also in general for all types supported by a node:

- *Total number of assigned requests:* The total number of past requests that an oracle has agreed to, both fulfilled and unfulfilled.
- *Total number of completed requests:* The total number of past requests that an oracle has fulfilled. This can be averaged over number of requests assigned to calculate completion rate.
- *Total number of accepted requests:* The total number of requests that have been deemed acceptable by calculating contracts when compared with peer responses. This can be averaged over total assigned or total completed requests to get insight into accuracy rates.
- *Average time to respond:* While it may be necessary to give oracle responses time for confirmation, the timeliness of their responses will be helpful in determining future timeliness. Average response time is calculated based on completed requests.
- *Amount of penalty payments:* If penalty payments were locked in to assure a node operator's performance, the result would be a financial metric of an oracle provider's commitment not to engage in an "exit scam" attack, where the provider takes users' money and doesn't provide services. This metric would involve both a temporal and a financial dimension.

High-reputation services are strongly incentivized in any market to behave correctly and ensure high availability and performance. Negative user feedback will pose a significant risk to brand value, as do the penalties associated with misbehavior. Consequently, we anticipate a virtuous circle in which well-functioning oracles develop good reputations and good reputations give rise to incentives for continued high performance.

### 5.3 Certification Service

While our Validation and Reputation Systems are intended to address a broad range of faulty behaviors by oracles and is proposed as a way to ensure system integrity in the vast majority of cases, ChainLink may also include an additional mechanism called a *Certification Service*. Its goal is to prevent and/or remediate rare but catastrophic events, specifically *en bloc* cheating in the form of Sybil and mirroring attacks, which we now explain.

**Sybil and mirroring attacks.** Both our simple and in-contract aggregation protocols seek to prevent freeloading in the sense of dishonest nodes copying honest nodes' answers. But neither protects against *Sybil attacks* [9]. Such attacks involve an adversary that controls multiple, ostensibly independent oracles. This adversary can attempt to dominate the oracle pool, causing more than  $f$  oracles to participate in the aggregation protocol and provide *false data* at strategic times, e.g., in order to influence large transactions in high-value contracts. Quorums of cheating oracles can also arise not just under the control of a single adversary, but also through collusion among multiple adversaries. Attacks or faults involving  $> f$  oracles are especially pernicious in that they are undetectable from on-chain behavior alone.

Additionally, to reduce operational costs, a Sybil attacker can adopt a behavior called *mirroring*, in which it causes oracles to send individual responses based on data obtained from a *single data-source query*. In other words, misbehaving oracles may share data off-chain but pretend to source data independently. Mirroring benefits an adversary whether or not it chooses to send false data. It poses a much less serious security threat than data falsification, but does slightly degrade security in that it eliminates the error correction resulting from diversified queries against a given source **Src**. For example, if `https://www.datasource.com` emits erroneous data due to, say, a sporadically triggered bug, multiple queriers may still obtain a correct majority result.

Sybil attacks resulting in false data, mirroring, and collusion in general may be eliminated by the use of trusted hardware in our long-term strategy (see Section 6).

**Certification Service design.** The ChainLink Certification Service would seek to provide general integrity and availability assurance, detecting and helping prevent mirroring and colluding oracle quorums in the short-to-medium term. The Certification Service would issue *endorsements* of high-quality oracle providers. We emphasize again, as noted above, that the service will only rate providers for the benefit of users. It is not meant to dictate oracle node participation or non-participation in the system.

The Certification Service supports endorsements based on several features of oracle deployment and behavior. It would monitor the Validation System statistics

on oracles and perform post-hoc spot-checking of on-chain answers—particularly for high-value transactions—comparing them with answers obtained directly from reputable data sources. With sufficient demand for an oracle provider’s data, we expect there to be enough economic incentive to justify off-chain audits of oracle providers, confirming compliance with relevant security standards, such as relevant controls in the Cloud Security Alliance (CSA) Cloud Controls Matrix [26], as well as providing useful security information that they conduct proper audits of oracles’ source and bytecode for their smart contracts.

In addition to the reputation metrics, automated on-chain and automated off-chain systems for fraud detection, the Certification Service is planned as a means to identify Sybil attacks and other malfeasance that automated on-chain systems cannot. For example, if all nodes agree that the moon is made of green cheese, they can cause `USER-SC` to ingest this false fact. `MOON COMPONENTS = {GREEN CHEESE}` will be recorded on the blockchain, however, and visible in a post-hoc review.

## 5.4 Contract-Upgrade Service

As recent smart contract hacks have shown, coding bulletproof smart contracts is an extremely challenging exercise [1], [20], [22]. And even if a smart contract has been correctly programmed, environmental changes or bugs can still result in vulnerabilities, e.g., [2].

For this reason, we propose a Contract-Upgrade Service. We emphasize that use of this service is entirely optional and in control of users.

In the short term, if vulnerabilities are discovered, the Contract-Upgrade Service would simply make a new set of supporting oracle contracts available in ChainLink. Newly created requesting smart contracts will then be able to migrate to the new set of oracle contracts.

Unfortunately, though, existing ones would be stuck with the old, potentially vulnerable set. In the longer term, therefore, `CHAINLINK-SC` would support a flag (`MIGFLAG`) in oracle calls from requesting contracts indicating whether or not a call should be forwarded to a new `CHAINLINK-SC` should one become available. Set by default (i.e., if the flag is missing) to `false`, `MIGFLAG` would enable requesting contracts to benefit from automatic forwarding and thus migration to the new version of `CHAINLINK-SC`. In order to activate forwarding, a user will cause her requesting contract to issue ChainLink requests with `MIGFLAG = true`. (Users can engineer their smart contracts so that they change this flag upon receiving an instruction to do so on-chain from an authorized contract administrator.)

Migration of users to new oracle contracts functions as a kind of “escape hatch,” something long advocated for by blockchain researchers (see, e.g., [23]) as a mechanism to fix bugs and remediate hacks without resorting to such cumbersome approaches as

whitehat hacking [1] or hard forks. Migration to the updated contracts will be visible on the blockchain, and available to audit for users to review before upgrading.

We recognize nonetheless that some users will not feel comfortable with any one group controlling an escape hatch in the form of migration / forwarding. Forced migration could empower the migrating contract’s controller, or a hacker who compromises relevant credentials, to undertake malicious activity, such as changing oracle responses. It is for this reason that requesting contracts have full control of the forwarding feature and can thus opt out of escape-hatch activation. Additionally, in accordance with ChainLink’s focus on decentralization, we expect that providers will be able to support multiple versions of CHAINLINK-SC developed by the community.

## 5.5 LINK token usage

The ChainLink network utilizes the LINK token\*\* to pay ChainLink Node operators for the retrieval of data from off-chain data feeds, formatting of data into blockchain readable formats, off-chain computation, and uptime guarantees they provide as operators. In order for a smart contract on networks like Ethereum to use a ChainLink node, they will need to pay their chosen ChainLink Node Operator using LINK tokens, with prices being set by the node operator based on demand for the off-chain resource their ChainLink provides, and the supply of other similar resources. The LINK token is an ERC20 token, with the additional ERC223 “transfer and call” functionality of `transfer(address,uint256,bytes)`, allowing tokens to be received and processed by contracts within a single transaction.

# 6 Long-Term Technical Strategy

The long-term technical strategy for ChainLink proposed in this whitepaper includes three key directions: Oracle confidentiality, infrastructure changes, and off-chain computation.

## 6.1 Confidentiality

A distributed oracle network aims to offer a high degree of protection against faulty oracles. In most deployment scenarios, it seeks to attain a correct response in the face of  $f$  Byzantine faults (for  $f < n/2$  in our simple aggregation protocol). Trusted hardware can offer much more and is proposed as a better approach to securing the ChainLink network. Trusted hardware is the keystone of the Town Crier (TC) oracle [24], which is currently operating on the Ethereum mainnet [33] and whose creators partnered with SmartContract in the TC launch.

Certain forms of trusted hardware, most notably Intel’s recent Software Guard eXtensions (SGX) set of instruction-set architecture extensions [12]–[15], [18], seek to provide a powerful adjunct to distributed forms of trust. Briefly, SGX permits an application to be executed in an environment called an enclave that claims two critical security properties. First, enclaves protect the integrity of the application, meaning its data, code, and control flow, against subversion by other processes. Second, an enclave protects the confidentiality of an application, meaning that its data, code, and execution state are opaque to other processes. SGX seeks to protect enclaved applications even against a malicious operating system, and thus against even the administrator of the host on which an application is running.

While alternative forms of trusted hardware, such as ARM TrustZone, have been in existence for some time, SGX provides an additional key feature lacking in these technologies. It enables a platform to generate an attestation to the execution of a particular application (identified by a build of its hash state). This attestation can be verified remotely and allows a specific application instance to be bound to a public key and thus to establish authenticated and confidential channels with other parties.

Running an oracle in an enclave and distributing attestations can provide very strong assurance that the oracle is executing a particular application, specifically one created or endorsed by developers in the ChainLink ecosystem. Additionally, an oracle running in an enclave that can connect to a data source via HTTPS can provide a strong assurance that the data it retrieves has not been tampered with. (See [24], [33] for details.) These properties go a long way toward protecting against oracle misbehavior in the sense of data corruption, Sybil attacks, etc.

A still greater opportunity, however, lies in the ability of trusted hardware to provide strong confidentiality. The need for confidentiality is in general one of the main hurdles to blockchain deployment. Confidentiality-preserving oracles can be instrumental in solving the problem.

**Why distributed oracles don’t ensure confidentiality.** Confidentiality is fundamentally hard to achieve in any oracle system. If an oracle has a blockchain front end such as a smart contract, then any queries to the oracle will be publicly visible. Queries can be encrypted on-chain and decrypted by the oracle service, but then the oracle service itself will see them. Even heavyweight tools such as secure multiparty computation, which permits computation over encrypted data, can’t solve this problem given existing infrastructure. (See, e.g., [11] for an application-oriented perspective.) At some point a server needs to send a query to a target data source server. Thus it must see the query, irrespective of whatever confidentiality the query previously enjoyed. It will also see the response to the query.

**Confidentiality-preserving oracles via SGX.** An oracle using SGX can ingest and process data within an enclave, in essence acting like a TTP trusted for integrity and confidentiality. To begin with, such an oracle can decrypt queries within its enclave. It can then process them without exposing them to any other process (or any human being). The enclave can also process data from sources confidentially and can securely manage sensitive information such as user credentials, a powerful capability, as we illustrate below.

The Town Crier system supports confidential flight data queries. Flight information can be passed to a TC smart contract front end encrypted under the public key of the TC service. TC decrypts the query and then contacts a data source (e.g., flightaware.com) over HTTPS. It returns to the querying smart contract a simple yes/no answer to the question “Has this flight been delayed?” and exposes no other information on-chain.

An even more interesting TC capability is its support for trading on the Steam gaming platform. TC can securely ingest user credentials (passwords) to check that game ownership has been transferred from a buyer to a seller. It can thereby create a secure marketplace that would be otherwise unachievable, with high assurance fair swaps of cryptocurrency for digital goods. (A simple distributed oracle, in contrast, could not securely manage users’ passwords on their behalf.)

TC can also perform trusted off-chain aggregation of data from multiple sources, as well as trusted computation over data from multiple sources (e.g., averaging) and interactive querying of data sources (e.g., searching the database of one source in response to the answer of another).

Trusted hardware offers an exciting new approach to the scalable usage of blockchains [24], [29], in which large portions of blockchain infrastructure, including smart contracts, execute in enclaves. Such an architecture would combine transparency benefits of blockchains with the confidentiality properties of off-chain execution and trusted hardware. While similar ideas have been suggested using other techniques, such as zk-SNARKs [21], trusted hardware is far more practical (and less complicated). Our current research agenda includes this expansive vision, with oracles as a catalyzing service.

We briefly discuss the issue of Intel as a root of trust in Appendix B.

**Defining security given SGX.** It is possible, given the use of trusted hardware, to define oracle correctness more formally, starting with the formalism for Intel SGX proposed in [32]. This formalism allows SGX to be treated as a global Universally Composable (UC) [6] functionality  $\mathcal{F}_{\text{sgx}}(\Sigma_{\text{sgx}})[\text{prog}_{\text{encl}}, \mathcal{R}]$ . Here, and in what follows,  $\Sigma$  denotes a signature scheme with signing and verification functions  $\Sigma.\text{Sign}$  and  $\Sigma.\text{Verify}$ . An instance of  $\mathcal{F}_{\text{sgx}}(\Sigma_{\text{sgx}})[\text{prog}_{\text{encl}}, \mathcal{R}]$  is parameterized by a group signature

scheme  $\Sigma_{\text{sgx}}$ . Argument  $\text{prog}_{\text{encl}}$  denotes the program running in an *enclave*, i.e., environment protected by the hardware.  $\mathcal{R}$  denotes the untrusted code running on an SGX host, i.e., the software that calls the application running in the enclave.

Figure 5 (taken from [24]) shows the operation of the functionality  $\mathcal{F}_{\text{sgx}}$ . Upon initialization, it runs  $\text{outp} := \text{prog}_{\text{encl}}.\text{Initialize}()$ , generating and attestation to the code of  $\text{prog}_{\text{encl}}$  and  $\text{outp}$ . An attestation  $\sigma_{\text{att}}$  is a digitally signed statement by the platform that  $\text{prog}_{\text{encl}}$  is running in an enclave and has yielded output  $\text{outp}$ . In typical usage,  $\text{prog}_{\text{encl}}.\text{Initialize}()$  outputs an instance-specific public key that can be used to create a secure channel to the application instance. Upon a resume call with  $(\text{id}, \text{params})$ ,  $\mathcal{F}_{\text{sgx}}$  continues execution and outputs the result of  $\text{prog}_{\text{encl}}.\text{Resume}(\text{id}, \text{params})$ , where  $\text{id}$  denotes a session identifier and  $\text{params}$  denotes parameters input to  $\text{prog}_{\text{encl}}$ .

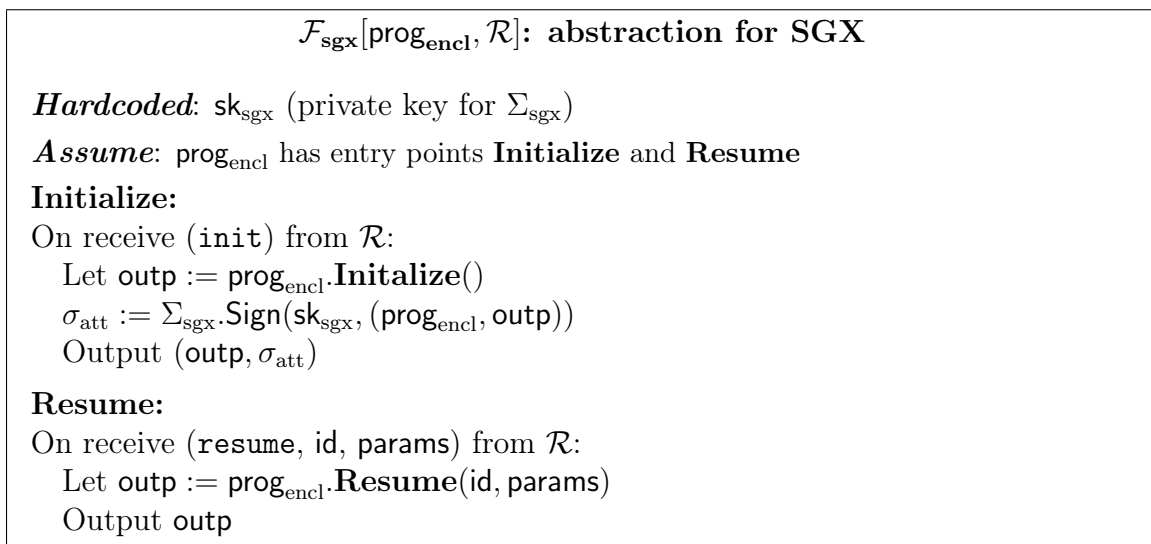

**Figure 5:** Formal abstraction for SGX execution capturing a subset of SGX features..

Given the formalism of Figure 5, it is possible to precisely define the integrity of an oracle. Definition 1 does so in a slight generalization of the definition given in [24] that we call *Authenticity of Oracle*.

**Definition 1** (Authenticity of Oracle). *We say that an oracle  $O$  running program  $\text{prog}_{\text{encl}}$  using  $\mathcal{F}_{\text{sgx}}$  and outputting instance key  $\text{pk}_O$  satisfies Authenticity of Oracle if, for any polynomial-time adversary  $\mathcal{A}$  that can interact arbitrarily with  $\mathcal{F}_{\text{sgx}}$ ,  $\mathcal{A}$  cannot cause an honest verifier to accept  $(\text{pk}_O, \sigma_{\text{att}}, \text{params} := (\text{url}, T), \text{data}, \sigma)$  where  $\text{data}$  is not the contents of  $\text{url}$  with the public key at time  $T$  ( $\text{prog}_{\text{encl}}.\text{Resume}(\text{id}, \text{params})$ ) in*



our model). More formally, for any probabilistic polynomial-time adversary  $\mathcal{A}$ ,

$$\Pr \left[ \begin{array}{l} (\text{pk}_O, \sigma_{att}, \text{id}, \text{params}, \text{data}, \sigma) \leftarrow \mathcal{A}^{\mathcal{F}_{sgx}}(1^\lambda) : \\ (\Sigma_{sgx}.\text{Verify}(\text{pk}_{sgx}, \sigma_{att}, (\text{prog}_{encl}, \text{pk}_O)) = 1) \wedge \\ (\Sigma.\text{Verify}(\text{pk}_O, \sigma, (\text{id}, \text{params}, \text{data})) = 1) \wedge \\ \text{data} \neq \text{prog}_{encl}.\text{Resume}(\text{id}, \text{params}) \end{array} \right] \leq \text{negl}(\lambda),$$

for security parameter  $\lambda$ .

## 6.2 Infrastructure changes

Many of the challenges in constructing secure oracles arise from the fact that existing data sources *don't digitally sign the data they serve*. If they did, then oracles would not need to be trusted to refrain from tampering with data. HTTPS, the protocol for secure web communications, does not enable data signing. It does, though, have an underlying public-key infrastructure (PKI) that requires servers to possess certificates that could in principle support data signing.

This observation is the basis of TLS-N, a TLS extension, that allows HTTPS servers to sign portions of their sessions with clients. The selective nature of the signing provides other nice features, such as the ability for clients to exclude from signed transcripts and thus protect the confidentiality of credentials (e.g., passwords) they use to connect to servers.

We believe infrastructure changes such as TLS-N are promising approaches to supporting oracle security. They will probably need to be used in concert with other technologies such as SGX, however, because of the following limitations:

1. *Infrastructure modifications*: Unfortunately, until and unless TLS-N becomes a standard, data sources must expressly deploy it for clients to benefit. Few data sources are likely to in the near future.
2. *Aggregation and computation*: TLS-N cannot support aggregation or other forms of trusted computation over data from data sources, so some trusted mechanism will still be required to accomplish these tasks.
3. *Cost*: Verification of TLS-N-signed data incurs relatively high on-chain costs compared with simple signature verification.
4. *Confidentiality*: TLS-N cannot support out-of-band confidential management of user credentials or queries, but instead requires users to query a data source *themselves* for this purpose. For example, confidential flight information cannot be stored in a smart contract for later confidential automated query of a website.

### 6.3 Off-chain computation

Some intriguing uses of oracles, such as the use of credential-dependent APIs, require that an oracle do considerably more than just transmit data. It may need to manage credentials, log into accounts to scrape data, and so forth. Indeed, given truly trustworthy and confidential oracles, something that SGX-backed systems à la Town Crier and techniques such as zero-knowledge proofs [21] can help achieve, the boundary between oracles and smart contracts may become fluid.

ChainLink already supports a regex-based language for queries that enables users to flexibly specify the processing of off-chain data. Our long-term strategy, however, seeks to create a world where oracles are a key off-chain computation resource used by most smart contracts. We believe this will be enabled by building towards a model of fully general, private off-chain computation *within oracles* whose results are consumed by smart contracts. If this can be achieved with strong security, as we believe it can, pushing costly and sensitive computation logic into oracles will result in better confidentiality, lower contract execution costs, and more flexible architectures.

## 7 Existing Oracle Solutions

ChainLink is designed to fill a pervasive need for new oracle technology in smart contract systems. Unfortunately today there is a very limited supply of highly secure and flexible oracle systems. We believe this lack of trustworthy oracles is a major impediment to the evolution of smart contracts.

The most commonly used option for oracle services today are centralized oracle providers. This approach is problematic as it creates a centralized point of control, and thus does not meet the high standards of tamper resistance that trustless smart contracts require. Some such systems, e.g. [31], attempt to remedy this problem by relying on notarization, to “prove” correct behavior. This use of notarization services is worrisome in view of documented problems with these services [37], and the fact that their attestations cannot be feasibly verified on-chain, resulting in a (potentially recursive) need for further verification.

Another approach to delivering trustworthy oracle data is to rely on manual human input of unstructured data. These “manual-input oracle” are commonly proposed for use in prediction-markets [17], [25], [28]. By creating appropriate financial stakes and assuming economically rational players with limited financial incentives for cheating, such oracles provide a high assurance of correct crowd-sourced answers. This approach is decentralized and flexible. Since manual-input oracles obtain their responses from human beings, they can respond to questions for which structured data is hard to find, or difficult to extract in a reliable way, e.g., requires natural language processing

of news events. Unfortunately, though, because human cognition is costly and slow, manual-input oracles are resource-intensive, not real-time, and can handle only a limited set of questions at any given time. We believe that ChainLink could also be very useful for quickly and automatically resolving prediction-market contracts that can be resolved by structured data.

A final approach is to change the form of data at the source. If a data source *digitally signed* the data it provided, then the relaying server wouldn't need to be trusted. USER-SC could simply check the signatures on data it receives. An excellent, general approach of this kind is provided by TLS-N, as discussed above. Unfortunately, as already mentioned, TLS-N requires changes to existing infrastructure.

## 8 Conclusion

We have introduced ChainLink, a decentralized oracle network for smart contracts to securely interact with resources external to the blockchain. We have outlined the ChainLink architecture, describing both on and off-chain components. After defining security in the context of oracles, we described ChainLink's multilayered approach to decentralization. We proposed a novel protocol with new features such as protection against freeloading (with additional protocols and security-proof sketches in the paper appendix). We also laid out a roadmap for how ChainLink can harness technological and infrastructural advances, such as trusted hardware and digital signing of data by sources. Finally, having examined existing oracle solutions and their shortcomings, we have exposed the need today for a system such as ChainLink.

**Design Principles.** As we continue our work on ChainLink, we will seek to prioritize the following core values:

- *Decentralization for secure and open systems.* Decentralization is not only the foundation of the tamperproof properties of blockchains, but the basis of their permissionless nature. By continuing to build decentralized systems, we aim to further enable permissionless development within the ecosystem. We believe that decentralization is a crucial component for a globally thriving ecosystem with long-term sustainability.
- *Modularity for simple, flexible system design.* We appreciate the philosophy of building small tools which do one thing well. Simple components can be easily reasoned about and thus securely combined into larger systems. We believe that modularity not only enables upgradable systems, but facilitates decentralization. Wherever key pieces of ChainLink depend on or are managed by too

few parties, we will seek to design an ecosystem which allows for competing implementations to be used.

- *Open source for secure, extensible systems.* ChainLink is made possible by standing on the shoulders of many open source projects. We value the community and will continue to contribute by developing ChainLink in an open source manner. We plan to engage continually with developers, academics, and security experts for peer review. We encourage testing, audits, and formal proofs of security, all with the aim of creating a platform whose robustness and security can support future innovations.

With these principles in mind, we look forward to extending the reach and impact of blockchains and smart contracts by making oracles a secure cornerstone of the ecosystem.

## References

- [1] Parity. *The Multi-sig hack: A postmortem*. <https://blog.ethcore.io/the-multi-sig-hack-a-postmortem/>. 20 July 2017.
- [2] Gun Sirer. *Cross-Chain Replay Attacks*. Hacking, Distributed blog. 17 July 2016.
- [3] Adi Shamir. “How to share a secret”. In: *Communications of the ACM* 22.11 (1979), pp. 612–613.
- [4] Claus-Peter Schnorr. “Efficient signature generation by smart cards”. In: *Journal of cryptology* 4.3 (1991), pp. 161–174.
- [5] Rosario Gennaro, Stanislaw Jarecki, Hugo Krawczyk, et al. “Secure distributed key generation for discrete-log based cryptosystems”. In: *Eurocrypt*. Vol. 99. Springer. 1999, pp. 295–310.
- [6] R. Canetti. “Universally Composable Security: A New Paradigm for Cryptographic Protocols”. In: *FOCS*. 2001.
- [7] Ran Canetti. “Universally composable security: A new paradigm for cryptographic protocols”. In: *Foundations of Computer Science, 2001. Proceedings. 42nd IEEE Symposium on*. IEEE. 2001, pp. 136–145.
- [8] Douglas R Stinson and Reto Strobl. “Provably secure distributed Schnorr signatures and a  $(t, n)$  threshold scheme for implicit certificates”. In: *ACISP*. Vol. 1. Springer. 2001, pp. 417–434.
- [9] John R Douceur. “The sybil attack”. In: *International Workshop on Peer-to-Peer Systems*. Springer. 2002, pp. 251–260.

- [10] Aniket Kate and Ian Goldberg. “Distributed key generation for the internet”. In: *Distributed Computing Systems, 2009. ICDCS’09. 29th IEEE International Conference on*. IEEE. 2009, pp. 119–128.
- [11] Claudio Orlandi. “Is multiparty computation any good in practice?” In: *Acoustics, Speech and Signal Processing (ICASSP), 2011 IEEE International Conference on*. IEEE. 2011, pp. 5848–5851.
- [12] Ittai Anati, Shay Gueron, Simon Johnson, et al. “Innovative technology for CPU based attestation and sealing”. In: *Proceedings of the 2<sup>nd</sup> International Workshop on Hardware and Architectural Support for Security and Privacy*. Vol. 13. 2013. URL: <https://software.intel.com/en-us/articles/innovative-technology-for-cpu-based-attestation-and-sealing> (visited on 05/23/2016).
- [13] Matthew Hoekstra, Reshma Lal, Pradeep Pappachan, et al. “Using Innovative Instructions to Create Trustworthy Software Solutions”. In: *Proceedings of the 2Nd International Workshop on Hardware and Architectural Support for Security and Privacy*. HASP ’13. Tel-Aviv, Israel: ACM, 2013, 11:1–11:1. ISBN: 978-1-4503-2118-1. DOI: 10.1145/2487726.2488370. URL: <http://doi.acm.org/10.1145/2487726.2488370>.
- [14] Frank McKeen, Ilya Alexandrovich, Alex Berenzon, et al. “Innovative instructions and software model for isolated execution.” In: *Proceedings of the 2nd International Workshop on Hardware and Architectural Support for Security and Privacy*. 2013, p. 10. URL: <http://css.csail.mit.edu/6.858/2015/readings/intel-sgx.pdf> (visited on 05/23/2016).
- [15] Intel. *Intel Software Guard Extensions Programming Reference*. 2014. (Visited on 05/23/2016).
- [16] Gavin Wood. “Ethereum: A secure decentralised generalised transaction ledger”. In: *Ethereum Project Yellow Paper* (2014).
- [17] Jack Peterson and Joseph Krug. “Augur: a decentralized, open-source platform for prediction markets”. In: *arXiv preprint arXiv:1501.01042* (2015).
- [18] Victor Costan and Srinivas Devadas. “Intel SGX Explained”. In: *Cryptology ePrint Archive* (2016). URL: <https://eprint.iacr.org/2016/086.pdf> (visited on 05/24/2016).
- [19] Victor Costan, Ilia A Lebedev, and Srinivas Devadas. “Sanctum: Minimal Hardware Extensions for Strong Software Isolation.” In: *USENIX Security Symposium*. 2016, pp. 857–874.

- [20] Kevin Delmolino, Mitchell Arnett, Ahmed Kosba, et al. “Step by step towards creating a safe smart contract: Lessons and insights from a cryptocurrency lab”. In: *International Conference on Financial Cryptography and Data Security*. Springer. 2016, pp. 79–94.
- [21] Ahmed Kosba, Andrew Miller, Elaine Shi, et al. “Hawk: The blockchain model of cryptography and privacy-preserving smart contracts”. In: *S&P’16*. IEEE. 2016.
- [22] Loi Luu, Duc-Hiep Chu, Hrishi Olickel, et al. “Making smart contracts smarter”. In: *Proceedings of the 2016 ACM SIGSAC Conference on Computer and Communications Security*. ACM. 2016, pp. 254–269.
- [23] Bill Marino and Ari Juels. “Setting standards for altering and undoing smart contracts”. In: *International Symposium on Rules and Rule Markup Languages for the Semantic Web*. Springer. 2016, pp. 151–166.
- [24] Fan Zhang, Ethan Cecchetti, Kyle Croman, et al. “Town Crier: An authenticated data feed for smart contracts”. In: *Proceedings of the 2016 ACM SIGSAC Conference on Computer and Communications Security*. ACM. 2016, pp. 270–282.
- [25] *Augur project page*. <https://augur.net>. 2017.
- [26] *CSA Cloud Controls Matrix*. URL: <https://cloudsecurityalliance.org/group/cloud-controls-matrix>. 2017.
- [27] Mark Flood and Oliver Goodenough. *Contract as Automaton: The Computational Representation of Financial Agreements*. [https://www.financialresearch.gov/working-papers/files/OFRwp-2015-04\\_Contract-as-Automaton-The-Computational-Representation-of-Financial-Agreements.pdf](https://www.financialresearch.gov/working-papers/files/OFRwp-2015-04_Contract-as-Automaton-The-Computational-Representation-of-Financial-Agreements.pdf). Office of Financial Research, 2017.
- [28] *Gnosis project page*. <https://gnosis.pm>. 2017.
- [29] *Hyperledger Sawtooth*. <https://intelledger.github.io/introduction.html>. 2017.
- [30] Abhiram Kothapalli, Andrew Miller, and Nikita Borisov. “SmartCast: An Incentive Compatible Consensus Protocol Using Smart Contracts”. In: *Financial Cryptography and Data Security (FC)*. 2017.
- [31] *Oraclize project page*. <http://www.oraclize.it>. 2017.
- [32] Rafael Pass, Elaine Shi, and Florian Tramer. “Formal abstractions for attested execution secure processors”. In: *Eurocrypt*. Springer. 2017, pp. 260–289.
- [33] *Town Crier Ethereum service*. <http://www.town-crier.org/>. 2017.

- [34] Florian Tramer, Fan Zhang, Huang Lin, et al. “Sealed-glass proofs: Using transparent enclaves to prove and sell knowledge”. In: *Security and Privacy (EuroSec&P), 2017 IEEE European Symposium on*. IEEE. 2017, pp. 19–34.
- [35] Vitalik Buterin et al. *Ethereum white paper*. <https://github.com/ethereum/wiki/wiki/White-Paper>.
- [36] *JSON Schema*. <http://json-schema.org/>.
- [37] Hubert Ritzdorf, Karl Wüst, Arthur Gervais, et al. *TLS-N: Non-repudiation over TLS Enabling Ubiquitous Content Signing for Disintermediation*. IACR ePrint report 2017/578. URL: <https://eprint.iacr.org/2017/578>.

## Disclosures

† Ari Juels is a faculty member at the Jacobs Institute at Cornell Tech. He co-authored this work in his separate capacity as an advisor to SmartContract ChainLink Ltd., in which he has a financial interest.

\* This whitepaper is being provided by SmartContract ChainLink, Ltd. (“SCCL”), a British Virgin Islands corporation, in support of the ChainLink Platform. Secure Asset Exchange, Inc. (“SAE”) dba SmartContract.com, is providing administrative, technical and other support to SCCL, including support of SCCL’s LINK Token sale, and is receiving compensation from SCCL. The technological, social and business structures utilizing blockchain technology are continually developing and will evolve for the foreseeable future. Accordingly, the plans, strategies and implementation details described in this whitepaper will likely evolve as well and, accordingly, may never be adopted. SCCL and SAE reserve all rights to develop or pursue additional or alternative plans, strategies or implementation details associated with the ChainLink Platform.

\*\* LINK Tokens are being sold by SCCL pursuant to the Terms and Conditions of the token sale terms available at <https://link.smartcontract.com/terms>. For complete details, review the terms. LINK Tokens are not securities, investments or currency, and are not sold or marketed as such. Also: participating in the sale involves significant technological and systemic risks; the sale is not open to individuals who reside in or are citizens of the United States or Canada. The sale period, duration, pricing, and other provisions may change, as stated in the token sale terms. The LINK Token sale involves known and unknown risks, uncertainties, and other factors that may cause the actual functionality, utility, or levels of use of LINK Tokens to be materially different from any projected future results, use, functionality or utility expressed or implied by SCCL in the terms.



## A Off-Chain Aggregation

To ensure both valid, signed answers and to prevent freeloading, our off-chain aggregation protocol, discussed in Section 4.2, will rely on a simple distributed protocol based on threshold signatures [8]. The benefit of this approach is that for a given query, a *single* signature can be generated off-chain by a collection of  $n$  oracle nodes. As a result, only a single authenticated message needs to be handled on-chain, instead of  $O(n)$  messages from distinct oracle nodes. This approach greatly reduces costs by comparison with those incurred by Algorithm 1. The idea can be further extended, as in [30], to aggregate the answers to multiple queries within a single threshold signature, an idea we don't explore here but may consider in our architecture.

Suppose that  $f < n/3$  oracles are faulty and  $t = f + 1$ . Faulty nodes may try to perform freeloading and/or any of a range of other dishonest behaviors, such as signing invalid answers.

Our complete protocol for off-chain aggregation consists of a pair of algorithms  $OCA = (\text{DistOracle}, \text{RewardOracles})$  for computing a signature  $\text{Sig}_{\text{sk}}[A]$  on value  $A = \text{Agg}(A_1, A_2, \dots, A_n)$ , for the majority function  $\text{Agg}$ . A simplified, single-round version of these protocols is shown respectively in Algorithms 2 and 3. The first is executed by the participating oracles, while the second is executed by an entity PROVIDER that may, as mentioned above, take the form of a smart contract.

Before presenting  $OCA$ , we give some basic background on Schnorr signatures and the threshold scheme for computing them given in [8].

**Schnorr signatures.** The Schnorr signature scheme makes use of a group  $\mathbb{G}$  of prime order  $p$  with generator  $g$  for which the discrete log problem is presumed to be hard. A user's key pair takes the form  $(\text{sk}, \text{pk}) = (x, y = g^x)$  for  $x \leftarrow_{\$} \mathbb{Z}_p^\times$ , where  $\mathbb{Z}_p^\times = \mathbb{Z}_p - 0$ . Without loss of generality, we denote group operations multiplicatively. Schnorr signatures may be computed over elliptic curve groups, and indeed typically are in modern crypto implementations. Figure 6 shows the Schnorr signature scheme.

**Threshold Schnorr signature scheme.** We make use of the threshold signature scheme of [8]. This scheme generates a global private / public keypair  $(\text{sk}, \text{pk})$ . It enables threshold generation of a full signature  $\text{Sig}_{\text{sk}}[m]$  for a desired message  $m$ .

In the initial key generation protocol, each player is assigned a key share  $x_i = \text{sk}_i$ . This setup is a one-time operation and can be done using a distributed key generation protocol, e.g., [5] or, for an asynchronous setting, [10].

To generate a signature, players (oracles in our setting) first perform a distributed key generation protocol, as for key-share generation at setup. The output of this protocol is a global ephemeral secret key  $e$ . Each player ( $O_i$ ) receives a (secret) share  $e_i$  of  $e$ .

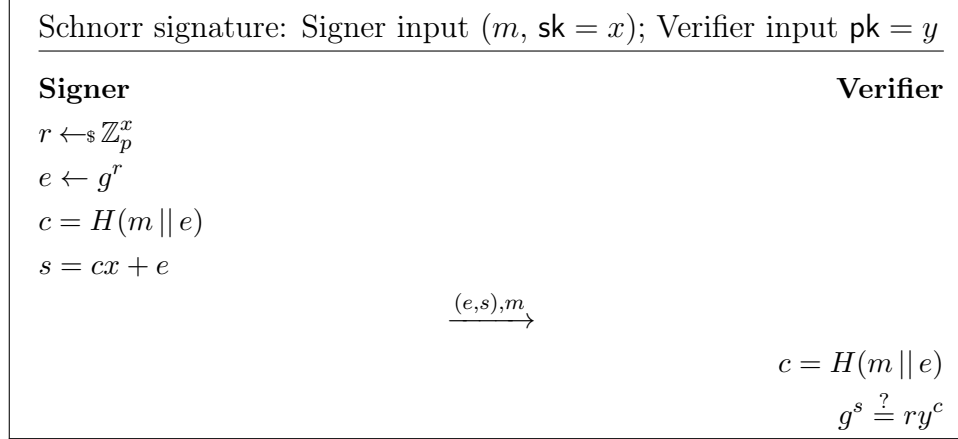

**Figure 6:** Schnorr signature scheme.

A partial signature of  $O_i$  given ephemeral key  $e$  takes the form  $\sigma_i^{(e)} = cx_i + e_i$ , where  $c = H(m || e)$ , as in the full signature. For each player  $O_i$  there also exists a function  $\text{valid}_i(\sigma_i; (\text{pk}, e))$  that verifies its partial signature. We refer to a partial signature as valid for  $O_i$  if it verifies correctly under  $\text{valid}_i$ .

We have somewhat modified notation and greatly condensed the scheme for our exposition here. We refer the reader to [8] for details.

## A.1 OCA protocol

We now present the `DistOracle` and `RewardOracles` algorithms that compose OCA. These are specified below in Algorithms 2 and 3. Using condensed notation (rather than including witnesses explicitly, as in Algorithm 1) we let `Commit` denote a commitment function.

Note that all players can see the messages received by `CHAINLINK-SC`, as it is on-chain. Let  $\Sigma^*$  be the first valid signature  $\Sigma$  sent to `CHAINLINK-SC`. In Alg. 3, we let  $PS^*$  denote a set of decommitments received by `PROVIDER` whose partial signatures yield  $\Sigma^*$ . ( $PS^*$  could come from the oracle that sent  $\Sigma^*$ , but need not. Any oracle with a partial signature in  $PS^*$  is incentivized to send  $PS^*$ .)

---

**Algorithm 2** DistOracle( $f, n, i, \text{sk}_i = x_i, \text{pk}, \text{Src}$ ) (code for  $O_i$ )

---

Jointly generate ephemeral key:

- 1: Execute distributed key-generation protocol and receive  $(e_i, e)$ .

Obtain data:

- 2: Obtain  $A_i$  from **Src**.

Generate partial signature:

- 3: Compute  $\sigma_i^{(e)}$  ( $= cx_i + e_i$ , for  $c = H(m || e)$ , where  $m = A_i$ ).

Commit round:

- 4: Broadcast commitment  $\text{comm}_i = (\text{Commit}(\sigma_i^{(e)}, A_i); i)$ .
- 5: Wait until a set  $C_i$  of  $n - f$  valid commitments from distinct oracles is received.
- 6: Send  $C_i$  to **PROVIDER**.

Prepare round:

- 7: Broadcast **prepared**.
- 8: Wait until  $n - f$  distinct **prepared** messages are received.

Reveal / decommit round:

- 9: Broadcast decommitment of  $(\sigma_i^{(e)}, A_i)$  for  $\text{comm}_i$ .
- 10: Wait until a set  $PS$  of  $\geq t$  valid decommitments are received.

Full signature computation:

- 11: **if** no valid  $\Sigma$  has yet been received by **CHAINLINK-SC** **then**
  - 12:       Aggregate partial signatures in  $PS$  into  $\Sigma = \text{Sig}_{\text{sk}}[A]$ .
  - 13:       Send  $\Sigma$  to **CHAINLINK-SC**.
  - 14:       Send  $PS$  to **PROVIDER**.
  - 15: **end if**
-

---

**Algorithm 3** RewardOracles (code for PROVIDER)

---

- 1: Wait until set  $\mathcal{C}$  of  $n - f$  commitment sets ( $C_i$ ) from distinct oracles and  $PS^*$  are received.
  - 2: **for** every oracle  $O_j$  **do**
  - 3:     **if**  $\sigma_j \in PS^*$  and  $> 2f$  sets in  $\mathcal{C}$  include commitments to  $\sigma_j$  from  $O_j$  **then**
  - 4:         Send  $\$reward$  to  $O_j$ .
  - 5:     **end if**
  - 6: **end for**
- 

## A.2 Proof sketches

We offer proof sketches of the key properties of OCA. We show that assuming at most  $f$  faulty nodes, the protocol always generates a valid signature on a correct answer, and never rewards freeloading oracle nodes.

**Claim 2.** *The protocol OCA will never reward a freeloading node.*

*Proof.* (Sketch) Suppose that  $O_z$  is freeloading. Then it can broadcast a valid commitment only after time  $\tau$ , the time at which the first honest  $O_i$  decommits in Step 9 of Alg. 2.  $O_i$  has received  $n - f$  **prepared** messages of which at least  $n - 2f$  come from honest nodes. Let  $O_j$  denote one of these at least  $n - 2f$  honest nodes.  $O_j$  will no longer accept commitments after sending a **prepared** message, so the set  $C_j$  of any such honest node  $O_j$  will no longer change after time  $\tau$ , and thus  $C_j$  will exclude a commitment with a correct partial signature  $\sigma_z$  from  $O_z$ . Therefore, at most  $n - (n - 2f) = 2f$  sets in  $\mathcal{C}$  in Alg. 3 will include  $O_z$ . Thus  $O_z$  will not receive a reward.  $\square$

Unfortunately, OCA cannot ensure that non-freeloading nodes are paid. A cheating adversary can, after receiving a decommitment, rush honest nodes in Step 13 of Alg. 2 by generating its own partial signatures and including only one honest node's partial signature in the generation of  $\Sigma$ . That honest node's commitment may not have been included among the  $n - f$  collected by any node. It could have come afterward.

**Claim 3.** *OCA will always result in a valid signature  $\Sigma = \text{Sig}_{sk}[A]$  eventually being sent to CHAINLINK-SC.*

*Proof.* (Sketch) There are  $n - f$  honest nodes, and  $f < n/3$ , so there are  $> 2f \geq f + 1$  honest nodes, and thus at least  $t$  honest nodes. So Step 1 of Alg. 2 will complete successfully.

Similarly, since there are  $n - f$  honest nodes, every oracle will eventually complete Step 7 of Alg. 2, sending a **prepared** message. Honest nodes will eventually then

receive at least  $n - f$  prepared messages and will decommit, permitting Step 13 to be completed by some honest node.  $\square$

**Claim 4.** *Any valid signature  $\text{Sig}_{\text{sk}}[A]$  received by CHAINLINK-SC in oca will be on a valid value  $A$ .*

*Proof.* (Sketch) It is easy to see that a valid signature  $\text{Sig}_{\text{sk}}[A]$  includes a correct value  $A$ . As  $t$  partial signatures are needed to compute  $\text{Sig}_{\text{sk}}[A]$ , and at most  $f < t$  nodes are faulty, at least one partial signature on  $A$  was provided by an honest node and thus it must be correct.  $\square$

### A.3 Discussion

OCA introduces a few design challenges that we briefly discuss here.

**Payment for honest nodes.** Unfortunately, while it penalizes freeloaders with non-payment, OCA is not able to guarantee conversely that honest nodes are paid. Indeed, even in the benign case where no nodes are faulty, unlucky message ordering can result in honest nodes that have contributed partial signatures to  $\Sigma$  not receiving payment.

This problem could be addressed in part by making Alg. 2 synchronous. Specifically, “Wait” steps could require that nodes wait a period of time  $\Delta$  such that receipt of messages from honest nodes is guaranteed. In this case, all nodes with partial signatures incorporated into  $\Sigma$  would be guaranteed payment. Side effects, however, would be slower execution and the challenge of setting  $\Delta$  correctly.

The problem of designing an asynchronous protocol with strong payment guarantees is an open research problem that we are currently exploring.

**Redundant messages.** OCA aims to minimize on-chain communication and ideally involves just one on-chain message, namely a signed response  $\Sigma$ , from the set of participating oracles. In practice, however, because a signature  $\Sigma$  will not post immediately to the blockchain, multiple oracles could independently send signed responses to the blockchain. The best way to limit such redundant messages is for oracles to monitor not just the blockchain, but the mempool, i.e., pending messages.

**Key management.** Of course, as is often the case, key management is a major challenge in protocols of this kind. The distribution of shares of  $\text{sk}$  can be performed in a distributed manner [5] and updates can be made to accommodate new nodes and remove departing nodes, as well as to provide proactive security, i.e., ongoing resilience against compromise of nodes’ keys. Additionally, nodes can be organized

into distinct cliques to bound the size of  $n$ . We propose that ChainLink employ these techniques to ensure a flexible, responsive, and secure distributed oracle.

## B SGX Trust Assumptions

In Intel’s role of providing stronger assurance of correctness, SGX enhances but does not supplant other integrity protections in ChainLink. In other words, use of SGX makes the system strictly stronger.

Trusting SGX for confidentiality does require trust in Intel, but this trust is circumscribed. Assuming that Intel does not have a backdoor in its CPUs enabling leakage of enclave data, it does not have a means of inspecting enclave state. (Such a backdoor is possible, but which would require the presence of physical evidence on every user’s machine and pose a serious reputational risk.)

Intel or an adversary that corrupts Intel’s manufacturing processes could in principle falsify attestation keys (platform EPID keys). Such an adversary could generate EPID keys that are not embedded in SGX-enabled servers, but instead permit attestations to be generated in a non-SGX platform. In effect, this adversary could create bogus servers that generate valid-looking SGX attestations, but provide no protections for enclaved code. Should there be more than  $f$  such nodes, of course, the adversary could corrupt oracle responses. More problematically, such nodes would expose sensitive data handled by oracle nodes to the adversary. The ability to falsify EPID keys, however, does not imply an ability to corrupt *existing*, valid SGX instances.

It is also important to recognize that of course today, whether or not we like it, trust in Intel is inescapable. The CPU in the machine on which you are reading this paper bears witness to this fact—or, if not, the CPU in the server from which you downloaded this paper.

Of course, it would be preferable to make use of trusted hardware from multiple vendors, and it is to be hoped that others will create equivalent capabilities. New, open architectures for trusted hardware, and ways to weaken the trust assumptions required of such hardware, are active areas of research, e.g., [19], [34]. The ability to diversify across vendors or architectures per se would not ensure data confidentiality, however.

We are also interested in research into techniques for confidentiality assurance in distributed networks through the use of cover traffic.